

Facial Recognition Using Deep Learning Neural Network

Shrinath Oza, Abdullah Khan, Nilabh Swapnil, Aayush Sharma, Jayashree Chaudhari

Student, Dr. D. Y. Patil School of Engineering, Pune, India
Student, Dr. D. Y. Patil School of Engineering, Pune, India
Student, Dr. D. Y. Patil School of Engineering, Pune, India
Student, Dr. D. Y. Patil School of Engineering, Pune, India
Professor, Dr. D. Y. Patil School of Engineering, Pune, India

ABSTRACT: By implementing Restricted Boltzmann Machine with the rules of deep learning and deep belief network, a facial recognition system algorithm is proposed. The algorithm will face images storing them as input and will store them in a database, after that a comparison will be made between the given input and already classified features in the database and dataset. The implementation of neural network and greedy layer wise training of the same network will ensure efficient and improved facial recognition system.

KEYWORDS: Facial recognition, Deep Learning, Neural Network, Deep Belief Network, Greedy Layer Algorithm,

I. INTRODUCTION

Facial recognition has become the norm with almost every device and every security system depending on it one way or other. With increased application of facial recognition the research on the same has increased exponentially. The main purpose of a facial recognition system is analysing, identifying and verifying a person from a digital image, video source or a database.

Despite immense research and development most of the facial recognition system struggle to accurately identify and detect a face. There are multiple factors that contribute to both accuracy and inaccuracy of the system viz. proper lightening, image clarity, and ambiance. Even though it is sometimes inaccurate, facial recognition systems play vital role in many areas like law enforcement, threat surveillance, fugitive hunt, smart cards, ATMs, driving license and passport to name a few. They are also widely implemented in day to day operations like entertainment in using human computer interaction, personal information and device security using face image as the passwords and commercial areas like telemarketing for authentication.

As the name suggests, neural networks are the computing systems inspired by the biological neural network in brain. They are a form of connectionism, where multiple individual units produce an interconnected network. Neural networks generally learn the functions and operations they have to perform progressively, improving day by day. These networks are generally created without task specific programming. ANN is based on collection of artificial neurons which are interlinked to each other. These links – ‘connections’ are called synapse. The neurons and connections (aka synapse) normally have a varying weight depending on the learning processes, typically organized in layers.

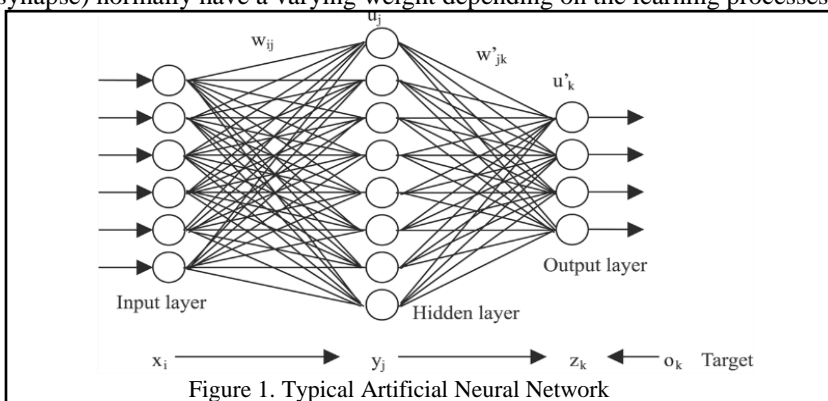

A. DEEP LEARNING FOR FACIAL RECOGNITION

Deep learning one of the methods of machine learning process which are based on learning data representation opposite to task specific algorithm. The deep learning algorithm being implemented can be supervised, partially supervised or unsupervised depending upon the requirement or operational environment. Deep learning can be implemented using various architectures such as deep neural network, deep belief network etc.

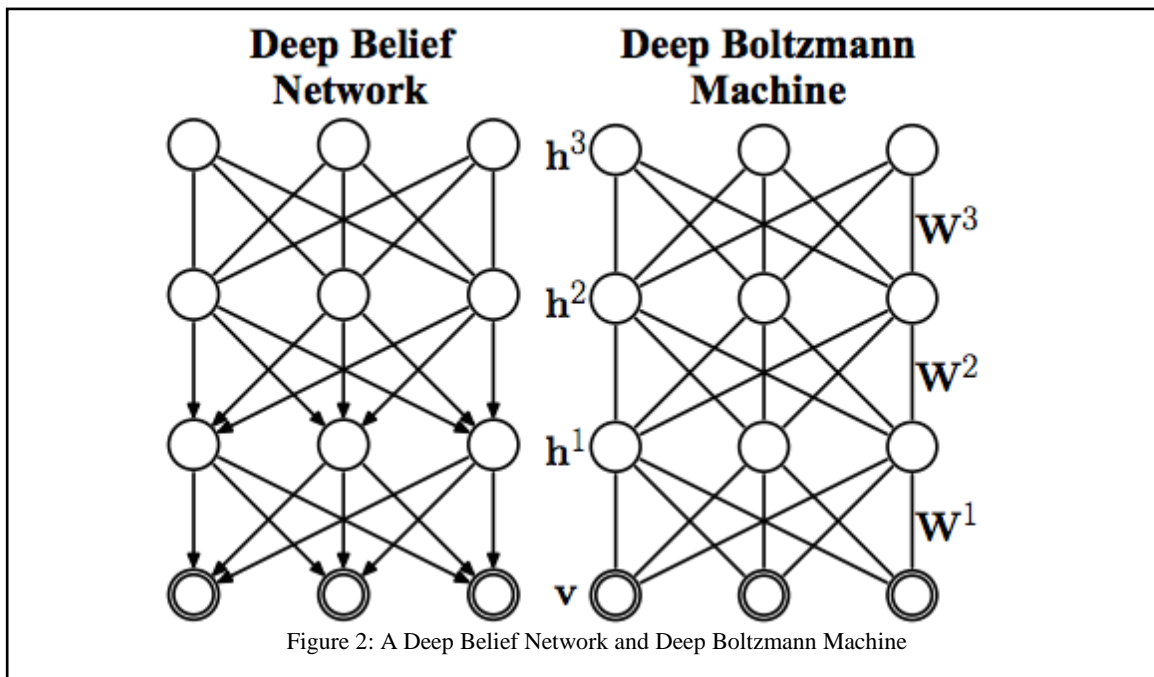

A deep belief network is a generative graphic model which is composed of multiple interconnected layers, where connections are between the layers but not between units within each layer. A deep belief network can learn to probabilistically (relating based on probability) its input when trained on an example set without supervision. Deep belief networks can be trained greedily, depending upon the requirement. Hinton [1][2] showed that deep belief network can be layered and stacked to form a Restricted Boltzmann Machine – RBM with a greedy, unsupervised approach.

Developed by Hinton [1], Restricted Boltzmann Machine (RBM) is an algorithm used for classification, collaborative filtering, dimensionality reduction and regression. RBM is an artificial neural network that can learn probability distribution over the given inputs. Similar to Deep Belief Network (DBN) Restricted Boltzmann Machine (RBM) can be trained supervised or unsupervised way, depending upon the requirement.

As the name suggests, RBM is a variant of Boltzmann Machine with a restriction that the layers within the RBM must form a bipartite graph. A pair nodes within different layers (namely ‘hidden’ and ‘visible’) can have a symmetric connection between them; and no connection between nodes within same layer. This restriction allows implication and execution of more efficient training algorithms.

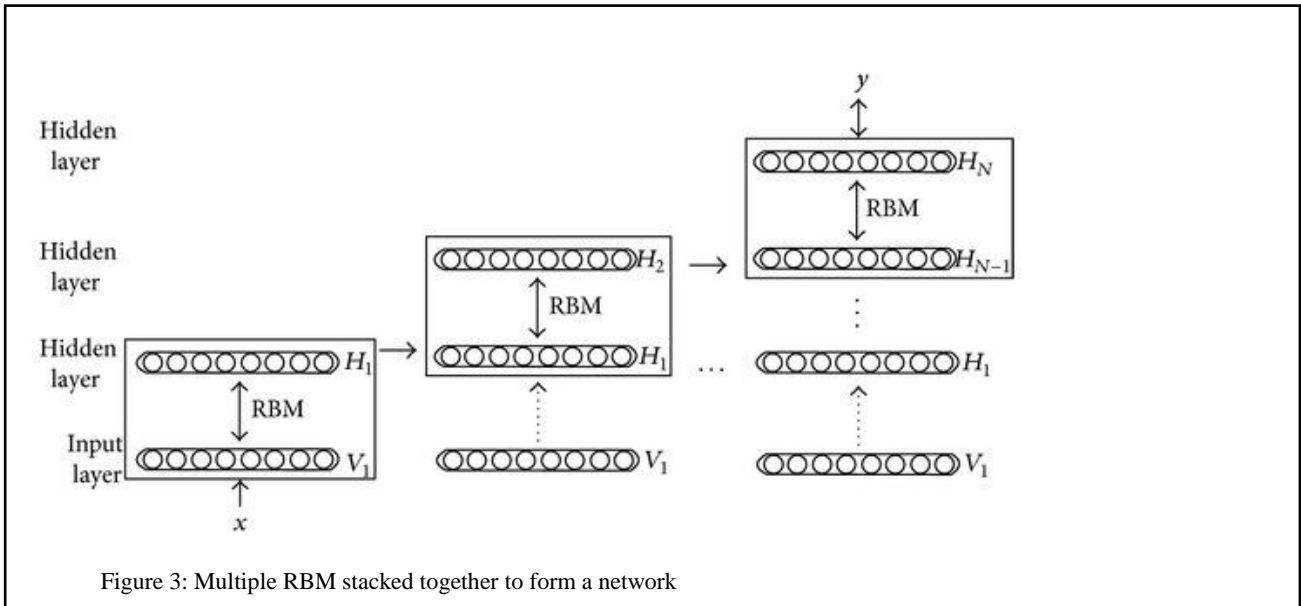

II. LITERATURE SURVEY

Sr. No.	Paper Title	Year	Methodology	Training Dataset
1.	Face Recognition from Video using Generalized Mean Deep Learning Neural	2016	Generalized Mean Method	Pasc and Youtube dataset
2.	Deep Learning Network for Face Detection	2015	multi-layer nonlinear mapping	
3.	An Incremental Face Recognition System Based on Deep Learning.	2017	S-Ddl Using SVM Algo.	FaceNet dataset training.
4.	Face Detection with Expression Recognition using Artificial Neural Networks	2016	MATLAB, Ann With Back Propagation	
5.	Face Recognition system in Android Using Neural Networks	2016	Feed Forward Algo, Back Propagation Algo	

[1] The algorithm in “Face Recognition from Video using Generalized Mean Deep Learning Neural” by Poonam Sharma and R. N. Yadav is a face recognition algorithm from video using generalized mean Deep Learning Neural Network. The generalized mean provided fast convergence of the feature set, enhancing the deep learning neural set. The algorithm was evaluated on PaSC and YouTube datasets. With the help of deep learning and neural network, good results were obtained. The results proved that the algorithm was better in terms of identifying faces accurately.

[2] In “Deep Learning Network for Face Detection” by Xueyi Ye, Xueting Chen, Huahua Chen, Yafeng Gu, and Qiuyun Lv multi-layer nonlinear mapping approach was taken. With the help of deep learning, semantic feature extraction was proposed for the face detection and identification to overcome the challenges of identifying and detecting faces accurately in non-ideal situations. The algorithm was made in a way that the number of neurons in the hidden layer decreased layer by layer to eliminate the redundant information of the input data. This helped in increasing detection speed of faces combined with the skin colour detection. Their proposed method possessed lower false detection and lower missing detection rate.

[3] In “An Incremental Face Recognition System Based on Deep Learning” the authors proposed and built a face recognition system which was also based on deep learning algorithm. The algorithm was implemented by OpenFace with the help of FaceNet network architecture. The system was made to improve classification with incremental SVM to achieve self-learning. So to boost the efficiency and effectiveness of the system. The algorithm was designed and implemented to update and optimize itself though the growing data amount. The mechanism allowed the proposed system to get more intelligent with the application time.

[4] The proposed system in “Facial Detection with Expression Recognition using Artificial Neural Network” was an automated vision system which was designed and implemented using MATLAB. The artificial neural network (ANN) in the system uses Multilayer Perceptron with back propagation. The system provided the ability to crop out faces placed in non-white backgrounds as well as the ability to recognize and classify multiple faces placed in the same image.

[5] In “Face Recognition system in Android Using Neural Networks” the system used feed forward and back propagation algorithm. The system was promising because using android as a platform widens the application and implementation area of the same algorithm. We can implement the system in smart houses, automobiles, healthcare systems and daily validation public systems and many more possible applications.

III. PROPOSED METHOD

In our algorithm, the facial identification and recognition process will be performed in multiple phases. First of all, the frames will be obtained by tracking the faces from the source input and after detecting the faces, facial features will be extracted. The feature extraction from the faces will be performed by deep learning architecture that is being implemented through the RBM. [3] These extracted features will be stored in the system and will be classified accordingly.

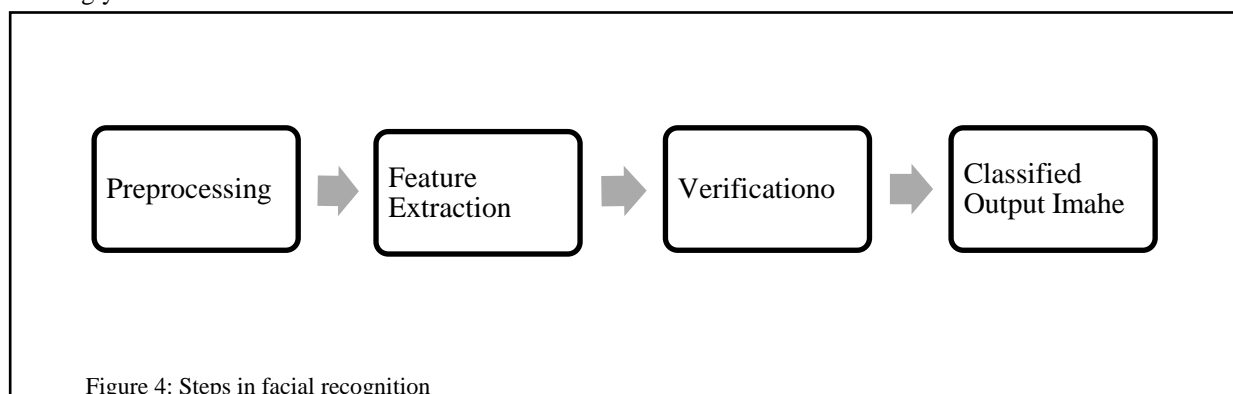

Figure 4: Steps in facial recognition

These stored features will be then compared with the MNIST database.

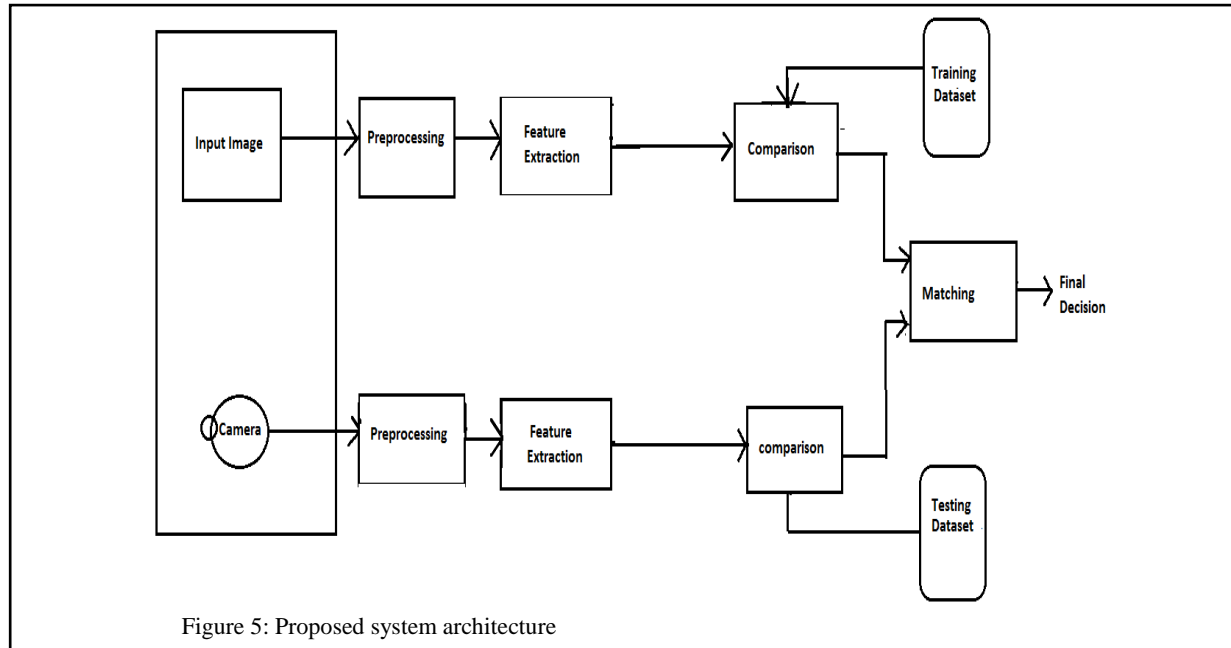

Figure 5: Proposed system architecture

MNIST or Modified National Institute of Standards and Technology database is a huge database which is most commonly used for training algorithms like ours for image processing. It was created by "re-mixing" the samples from NIST's original datasets. The particular reason to use MNIST as dataset is because MNIST is a huge dataset, containing over 60,000 training images and 10,000 testing images. This provides us with a plethora of options and comparisons to be made to test the system.

By implementing deep learning and a layered neural network [4], we are trying to reduce the error in identification of faces. If there are some inaccuracies or error, the deep belief network will learn from it as we are implementing it will greedy layer wise learning approach. The same shall reduce the error or inaccuracies greatly and the system is supposed to work more efficiently and accurately than other facial recognition system.

The system should detected the variance in skin colour and should be able to recognize and identify the faces even with angular rotation [4].

IV. CONCLUSION

While running the algorithm, the inputs will be given to the system, where it will make the comparisons. The results that will be yielded will prove that the proposed algorithm can detect faces accurately and can provide accurate results in detecting the faces with varying skin colours. It can also detect the rotated faces accurately.

REFERENCES

- [1] "A Practical Guide to Training Restricted Boltzmann Machines", Geoffrey Hinton.
- [2] "Deep belief networks", Geoffrey Hinton, (2009), Scholarpedia. 4 (5): 5947.
- [3] "Face Recognition from Video using Generalized Mean Deep Learning Neural Network" Poonam Sharma, R.N Yadav, K.V Arya - 2016 4th International Symposium on Computational and Business Intelligence.
- [4] "Deep Learning Network for Face Detection" Xueyi Ye, Xueting Chen, Huahua Chen, Yafeng Gu, Qiuyun Lv- 978-1-4673-7005-9 /2015 IEEE.
- [5] "An incremental face recognition system based on deep learning", Lufan Li, Zhang Jun, Jiwei Fei, Shuhao Li, DOI: 10.23919/MVA.2017.7986845, IEEE.
- [6] "Facial Detection with Expression Recognition using Artificial Neural Network", Michel Owayjan, Roger Achkar, Moussa Iskandar. DOI: 10.1109/MECBME.2016.7745421, IEEE.
- [7] "Face Recognition system in Android Using Neural Networks", Stoimen Stoimenov, Georgi T. Tsenov, Valeri M. Mladenov. DOI: 10.1109/NEUREL.2016.7800138, IEEE.