



ISSN: 2350-0328

**International Journal of Advanced Research in Science,  
Engineering and Technology**

**Vol. 5, Issue 11, November 2018**

# **Real Time Transformer Health Monitoring System using IOT**

**D.Sarathkumar, Uvaraj.M, Kabilesh Kumar C V, Kalaiselvi A**

Assistant Professor, Department of Electrical and Electronics Engineering,<sup>4</sup> Kongu Engineering College, Perundurai, Tamilnadu, India

Under Graduate Student, Department of Electrical and Electronics Engineering,<sup>4</sup> Kongu Engineering College, Perundurai, Tamilnadu, India

Under Graduate Student, Department of Electrical and Electronics Engineering,<sup>4</sup> Kongu Engineering College, Perundurai, Tamilnadu, India

Under Graduate Student, Department of Electrical and Electronics Engineering,<sup>4</sup> Kongu Engineering College, Perundurai, Tamilnadu, India

**ABSTRACT:** The main aim of the paper is to acquire real-time data of transformer remotely over the internet falling under the category of Internet of Things (IOT). For this real-time aspect, we take one temperature sensor, one potential transformer and one current transformer for monitoring T, V, I data of the transformer and then send them to a remote location. These three analog values are taken in multiplexing mode and connected to a programmable microcontroller of 8051 families through an ADC 0808. They are then sent directly to a Wi-Fi module under TCP IP protocol to a dedicated IP that displays the data in real-time chart form in any web connected PC / Laptop for display in 3 different charts. So, This Transformer Health Measuring will help to identify or recognize unexpected situations before any serious failure which leads to a greater reliability and significant cost savings.

**KEY WORDS:** Distributed Transformer, IOT, Microcontroller, Transformer health monitoring, Sensors, Wi-Fi module, PC / Laptop.

## **I.INTRODUCTION**

Electricity plays an important role in our life. Every moment of our life depends upon electricity. Electricity has several components and equipment helping human to transfer and regulate the distribution according to usage. The most crucial equipment of transmission and distribution of electric power is transformer. In Power system, an electrical component transformer directly distributes power to the low-voltage users and its operation condition is an criteria of the entire network operation. The majority of the devices have been in service for many years in different (electrical, mechanical, environmental) conditions. They are the main components and constitute the large portion of capital investment. Operation of distribution transformer under rated condition (as per specification in their name plate) guarantees their long service life. However their life is significantly reduced if they are subjected to overloading, heating low or high voltage current resulting in unexpected failure and loss of supply to a large number of customers thus is effecting system reliability. Overloading, oil temperature load current and ineffective cooling of transformer are the major cause of failure in distribution transformer. As a large number of transformers are distributed over a wide area in present electric systems, it's difficult to measure the condition manually of every single transformer. So we need a distribution transformer system to monitor all essential parameters operation, and send to the monitoring system in time. It provides the necessary information about the health of the transformer. This will help and guide the utilities to optimally use the transformer and keep this equipment in operation for a longer period.

This Proposed project presents design and implementation of a IOT embedded system to measure load currents, over voltage, transformer oil level and oil temperature. This is implemented by using on-line measuring system using Internet of Things (IOT), with single chip Arduino microcontroller and sensors. It is installed at the distribution transformer site. The output values of sensors are processed and recorded in the system memory. System programmed with some predefined instructions to check abnormal conditions. If there is any abnormality on the system, details are automatically updated in the internet through serial communication. This Internet of Things (IOT) will help the utilities to optimally utilize transformers and identify problems before any catastrophic failure occurs. Thus online-measuring system is used to collect and analyze temperature data over time. So Transformer Health Measuring will



help to identify or recognize unexpected situations before any serious failure which leads to a greater reliability and significant cost savings.

Transformer is one of the important electrical equipment that is used in power system. Monitoring transformer for the problem before they occur can prevent faults that are costly to repair and result in a loss of electricity. Currently, failure of the transformer can be detected by color changing of silica gel and decreasing the quality and viscosity of oil.

The main aim of the project is to acquire real-time data of transformer remotely over the internet falling under the category of Internet of Things (IOT).

1. For this real-time aspect, we take one temperature sensor, one potential transformer and one current transformer for monitoring Temperature(T), Voltage(V), Current (I) data of the transformer and then send them to a remote location.
2. These three analog values are taken in multiplexing mode and connected to a programmable microcontroller of 8051 families through an ADC 0808.
3. They are then sent directly to a Wi-Fi module under TCP IP protocol to a dedicated IP that displays the data in real-time chart form in any web connected PC / Laptop for display in different charts. The real-time data is also seen at the sending end LCD display interfaced with the microcontroller.

## II. LITERATURE SURVEY

In most power companies, for online monitoring of power transformers, use supervisory control and data acquisition (SCADA) system, but for online monitoring of power transformer, the extending the SCADA system is an expensive proposition. Power transformers are currently monitored manually, where a person visits a transformer site, for maintenance and taking records purpose. But main drawbacks of these systems are, it cannot provide information about overloads (Voltage & Current) and overheating of transformer oil & windings. Due to these , the transformer life is reduced.

Monika Agarwal et al. [1] This paper represents that they are designing a system where there exists communication between system and operator. For this we are using Transformer, microcontroller, logic level converter and GSM i.e. global system for mobile communication modem. This GSM modem helps to monitor transformer health by sending message to the system.

Hongyan Mao, et al. [2] This paper represents a large number of power distribution transformer stations and they are far away from city, wireless GPRS transmission provides a good communication solution to supervise power distribution transformer stations. The scheme of remote wireless monitoring system for power distribution transformer station based on GPRS wireless network was designed in this paper. A control terminal system implement was mainly given, which adopted LPC2132 as main processor, GR47 as the date communication module. The monitor terminal software and flow chart were also designed. At last, the way of configuring the GPRS module to connect network is analyzed.

Pathak A.K, et al. [3] This paper represents a design and implementation of a mobile embedded system to monitor and record key parameters of a distribution transformer like load currents, oil level and ambient Modem, with a standalone single chip microcontroller and different sensors. It is installed at the distribution transformer site and the above parameters are recorded using the analog to digital converter (ADC) of the embedded system. The obtained parameters are processed and recorded in the system memory. If any abnormality or an emergency situation occurs the system sends SMS (short message service) messages to the mobile phones containing information about the abnormality according to some predefined instructions programmed in the microcontroller. This mobile system will help the transformers to operate smoothly and identify problems before any catastrophic failure.

Disadvantage of Existing System

1. Firing of transformer can easily occurs.
2. Not accurate.
3. Frequency interference in system.
4. Noise problem in network.

## III. METHODOLOGY

The main objective of the proposed project is to acquire real-time data of transformer remotely over the internet falling under the category of Internet of Things (IOT). For this real-time aspect, we take one temperature sensor, one potential transformer and one current transformer for monitoring T, V, I data of the transformer and then send them to a remote location. These three analog values are taken in multiplexing mode and connected to a

programmable microcontroller of 8051 families through an ADC 0808. Then the values of all the sensors are sent sequentially as per the frequency of multiplexing of the ADC by Microcontroller. They are then sent directly to a Wi-Fi module under TCP IP protocol to a dedicated IP that displays the data in real-time chart form in any web connected PC / Laptop for display in different charts. The real-time data is also seen at the sending end LCD display interfaced with the microcontroller.

**MAIN BLOCK DIAGRAM**

Fig1. MAIN BLOCK DIAGRAM OF THE PROPOSED SYSTEM

**A) PROJECT DESCRIPTION**

A 230V AC supply is given to the 12 -0-12v transformer. If any fault occurs in transformer while operating, its fault can be sensed using different sensors. Voltage is sensed by bridge rectifier. Current is sensed by using current sensor, Temperature can be detected by using DHT11. All the analog signal is converted into digital by ADC. Voltage is regulated by using 5v voltage regulator. Output is viewed in phone by BLYNK WEB SERVER through NODE MCU wifi module.

**B) HARDWARE DESIGN:**

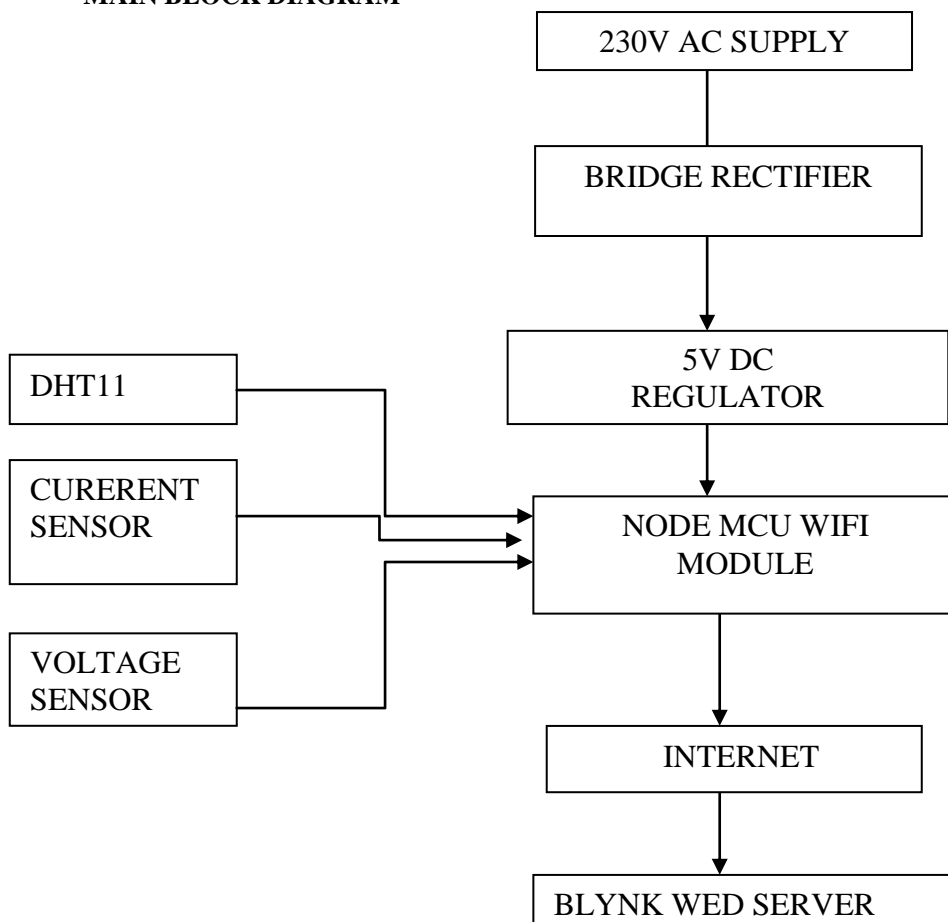
The block diagram shows Distribution transformer condition with NODE MCU with different sensors such as current sensor, temperature sensor, voltage sensor comes in hardware design as input devices at Remote Terminal Unit (RTU). After getting all parameter values from microcontroller are displayed on liquid crystal display and similarly on web page.

Node mcu module sends all parameter values to webpage as online interface to engineers. If any emergency condition occurs like overvoltage, over current increased temperature range, abnormality in vibrations and change in

humidity affects the transformer life, so we are informing engineers by giving notification by SMS through Node mcu, as well as displaying on monitor. At monitoring node whole system can be accessed by webpage.

## 1. TRANSMITTER SIDE

A 230v dc supply is given to the bridge rectifier. It will rectifier the input voltage then it is fed to the 5v regulator it will regulate input voltage to 5v .

Then the output of the regulator if given to the node mcu which is wifi module it acts like main block of this project.

The output of the project is viewed in blynk web server through internet. In this output can be viewed as digital. Output of three sensors namely voltage, current, and temperature. There are three sensors which it is the input of the node mcu wifi module. Three sensors are DTH11, current sensors ,voltage sensor.

## 2. RECEIVER SIDE

Receiver side plays major role in this project. There are two block in this receiver side internet and blynk web server.

Blynk web server is an app which can viewed through mobile phone. When there is any fault occurs in transformer, the digital output will displayed in phone.

## C) SOFTWARE DESIGN:

The software requirements document is the specification of the system. It should include both a definition and a specification of requirements. It is a set of what the system should do rather than how it should do it. The software requirements provide a basis for creating the software requirements specification. It is useful in estimating cost, planning team activities, performing tasks and tracking the teams and tracking the team's progress throughout the development activity. **Tools: NODE MCU**

## IV. HARDWARE IMPLEMENTATION OF THE PROPOSED SYSTEM

### OVERALL SYSTEM DESIGN

The system design consists of two parts:

#### A) Hardware Design:

The block diagram shows Implementation of transformer condition monitoring hardware setup of computer aided design using 3D modelling. PIC 18F4550 Microcontroller with different sensors such as current sensor, temperature sensor, voltage sensor comes in hardware design as input devices at Remote Terminal Unit (RTU). After getting all parameter values from microcontroller are displayed on liquid crystal display and similarly on web page.

PIC Microcontroller module sends all parameter values to webpage as online interface to engineers. If any emergency condition occurs like overvoltage, over current, rise and fall of oil level, increased temperature range, abnormality in vibrations and change in humidity affects the transformer life, so we are informing engineers by giving notification by SMS through GSM, as well as displaying on LCD with buzzer sound at Remote Terminal Unit (RTU). At monitoring node whole system can be accessed by webpage. The proposed system is discussed below:

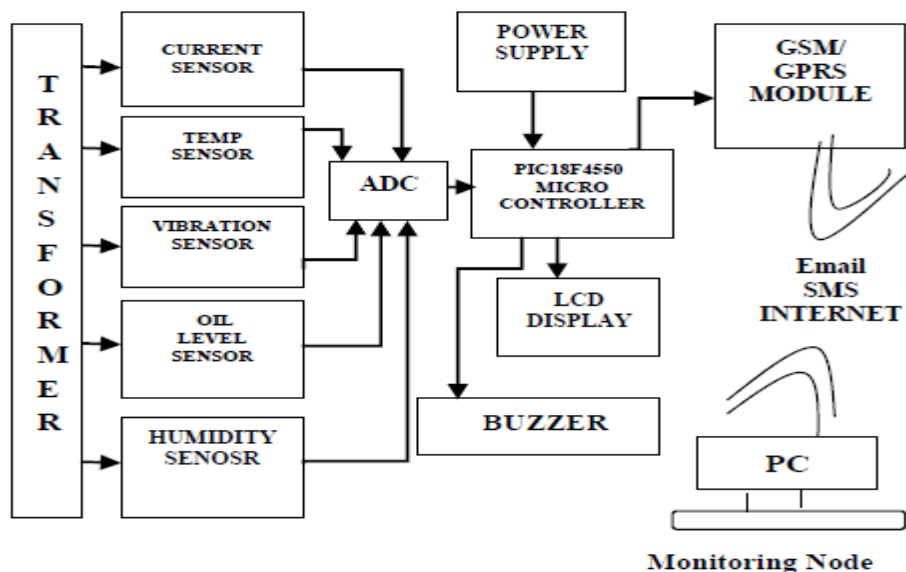

Fig2. BLOCK DIAGRAM OF OVERALL SYSTEM DESIGN

The minimum hardware requirements of the proposed system are as listed below.

- 1) Transformer
- 2) Voltage Sensor
- 3) Temperature Sensor (LM35)
- 4) Current Sensor
- 5) Ethernet shield
- 6) Relay
- 7) Power supply
- 8) Analog to Digital Converter (ADC)
- 9) PIC Micro controller
- 10) GSM/GPRS Module
- 11) LCD Module
- 12) Buzzer
- 13) Interfacing Cable
- 14) IOT Module and Control
- 15) Personal Computer or Laptop

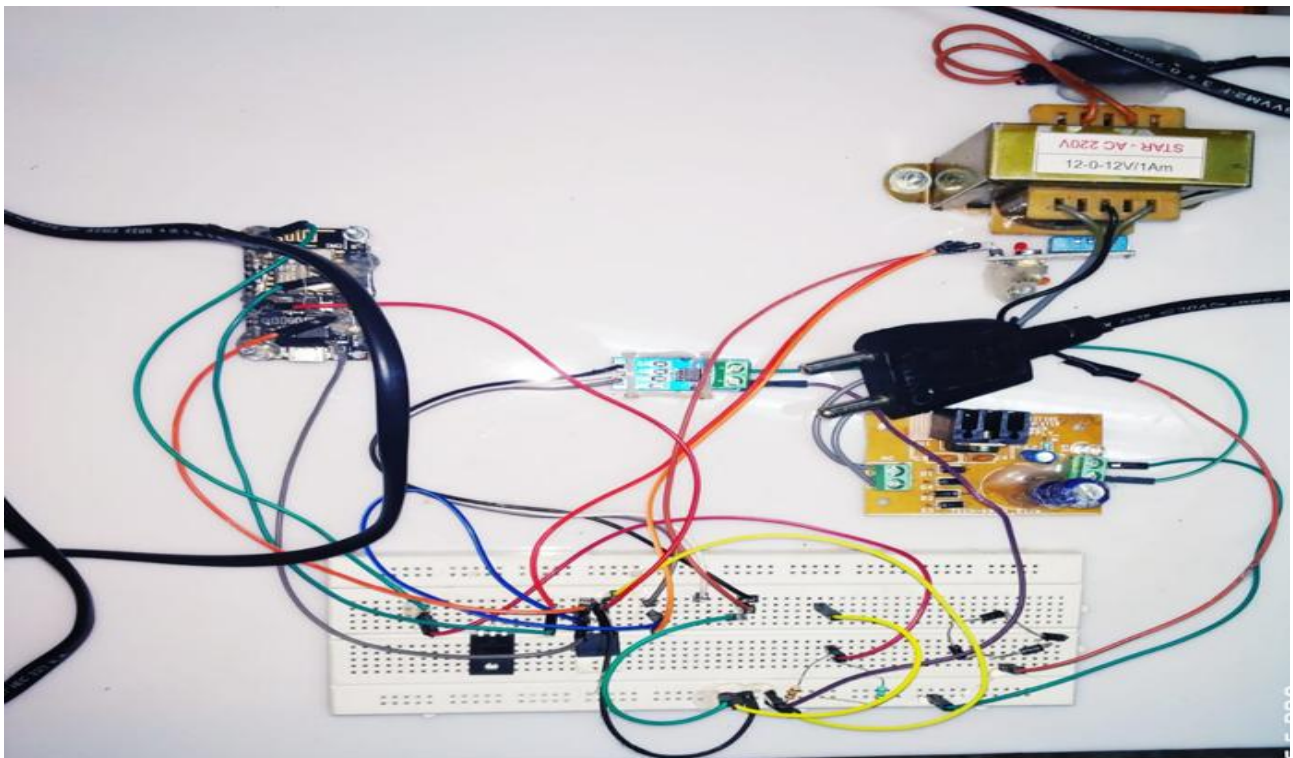

Fig. 3. **HARDWARE IMPLEMENTATION OF THE PROPOSED SYSTEM**

**ALGORITHM OF PROPOSED SYSTEM:**

- 1) Start
- 2) Initialize proposed system with button switch.
- 3) All sensors such as current sensor, temperature sensor, oil level sensor, vibration sensor and humidity sensor take the reading from the transformer.
- 4) All analog values are sent to ADC to convert them into digital.
- 5) Digital values are passed to PIC 18F4550 microcontroller.
- 6) PIC 18F4550 display these values on LCD.
- 7) Microcontroller sends these values on webpage IP address.
- 8) If any emergency condition occurs then immediately SMS is sent to engineers present over there through GSM.



ISSN: 2350-0328

# International Journal of Advanced Research in Science, Engineering and Technology

Vol. 5, Issue 11, November 2018

- 9) Buzzer beeps for indication at RTU side.
- 10) Webpage Valued box will blow red to alert online.
- 11) All the data values are saved in database periodically.
- 12) End.

## B) SOFTWARE DESIGN

### POWER PROGRAM:

```
#define BLYNK_PRINT Serial
#include <ESP8266WiFi.h>
#include <BlynkSimpleEsp8266.h>
#include <DHT.h>

// You should get Auth Token in the Blynk App.
// Go to the Project Settings (nut icon).
char auth[] = "b7f2fbee2d61425eb7ff15b2b12abddb";
// Your WiFi credentials.
// Set password to "" for open networks.
char ssid[] = "hello";
char pass[] = "12341234";
#define DHTPIN 2 // What digital pin we're connected to
// Uncomment whatever type you're using!
#define DHTTYPE DHT11 // DHT 11
// #define DHTTYPE DHT22 // DHT 22, AM2302, AM2321
// #define DHTTYPE DHT21 // DHT 21, AM2301
WidgetLCD lcd(V1);
DHT dht(DHTPIN, DHTTYPE);
BlynkTimer timer;

// This function sends Arduino's up time every second to Virtual Pin (5).
// In the app, Widget's reading frequency should be set to PUSH. This means
// that you define how often to send data to Blynk App.

void sendSensor()
{
  float h = dht.readHumidity();
  float t = dht.readTemperature(); // or dht.readTemperature(true) for Fahrenheit
  if (isnan(h) || isnan(t)) {
    Serial.println("Failed to read from DHT sensor!");
```



ISSN: 2350-0328

# International Journal of Advanced Research in Science, Engineering and Technology

Vol. 5, Issue 11, November 2018

## V. CONCLUSION & FUTURE SCOPE

### CONCLUSION

The proposed technique with results has shown that the protection scheme works properly with accuracy, sensitivity of this scheme very high for the abnormal and faulty conditions. Transformer Health Monitoring will help to identify or recognize unexpected situations before any serious failure which leads to greater reliability and significant cost savings. If transformer is in abnormal condition we can know from anywhere. No human power need to monitor the transformer. Details about the transformer are automatically updated in webpage when the transformer is in abnormal condition.

### FUTURE SCOPE

In future work we can develop database of all parameters of distribution transformer which are placed at different places. We can get all information by placing the proposed system modules at every transformer. We can send the data through Wifi module and also through Ethernet shield. With Ethernet shield we can make remote terminal unit as a server and store data on webpage or website. A Wifi module connects to nearby network and sends information to monitoring node.

### REFERENCES

- [1] Monika Agarwal and Akshaypandya, "GSM Based Condition Monitoring of Transformer", IJSRD - International Journal for Scientific Research&Development| Vol. 1, Issue 12, 2014 | ISSN (online): 2321-0613
- [2] Hongyan Mao, "Research of Wireless Monitoring System in Power Distribution Transformer Station Based on GPRS", Volume 5, C 2010 IEEE,978-1-4244-5586-7/10/\$26.00
- [3] Pathak A.K, Kolhe A.N, Gagare J.T and Khemnar SM, "GSM Based Distribution Transformer Monitoring And Controlling System", Vol-2 Issue-2 2016, IJARIE-ISSN (O)-2395-4396.
- [4]J. H. Estrada, S. Valencia Rami´rez, C. L. Cortés, E. A. Cano Plata, "Magnetic Flux Entropy as a Tool to Predict Transformer's Failures", Magnetics IEEE Transactions on, vol. 49, pp. 4729-4732, 2013, ISSN 0018-9464
- [5]. Chan, W. L, So, A.T.P. and Lai, L., L.; "Interment Based Transmission Substation Monitoring", IEEE Transaction on Power Systems, Vol. 14, No. 1, February 2014, pp. 293-298.
- [6].Zhang Xin, Huang Ronghui, Huang Weizhao, Yao Shenjing,Hou Dan & Zheng Min,"Real-time Temperature Monitoring System Using FBG Sensors on immersed PowerTransformer",DOI:10.13336/j.10036520.hve.2014.S2.048,Vol.40, Supplement 2: 253-259v, August 31, 2014.
- [7].Performance Monitoring of Transformer Parameters in (IJREEICE) Vol. 3, Issue 8, August 2015.
- [8]. GSM based Transformer Condition Monitoring System Ms.Swati R.Wandhare, Ms.Bhagyashree Shikkewal Special Issue-2 ISSN : 24541311 International Conference on Science and Engineering for Sustainable Development (ICESD 2017)(www.jit.org.in)International Journal of Advanced Engineering, Management and Science (IAEMS).
- [9]. Leibfried, T, "Online monitors keep transformers in service", Computer Applications in Power, IEEE, Volume: 11 Issue: 3, July, 2017. International Journal of Pure and Applied Mathematics Special Issue 963
- [10]. Chan, W. L, So, A.T.P. and Lai, L., L.; "Interment Based Transmission Substation Monitoring", IEEE Transaction on Power Systems, Vol. 14, No. 1, February 2014, pp. 293-298.
- [11].Zhang Xin, Huang Ronghui, Huang Weizhao, Yao Shenjing,Hou Dan & Zheng Min,"Real-time Temperature Monitoring System Using FBG Sensors on immersed PowerTransformer",DOI:10.13336/j.10036520.hve.2014.S2.048,Vol.40, Supplement 2: 253-259v, August 31, 2014.
- [12]. Performance Monitoring of Transformer Parameters in (IJREEICE) Vol. 3, Issue 8, August 2015.
- [13].. GSM based Transformer Condition Monitoring System Ms.Swati R.Wandhare, Ms.Bhagyashree Shikkewal Special Issue-2 ISSN : 24541311 International Conference on Science and Engineering for Sustainable Development (ICESD-2017)(www.jit.org.in)International Journal of Advanced Engineering, Management and Science (IAEMS).
- [14]. Leibfried, T, "Online monitors keep transformers in service", Computer Applications in Power, IEEE, Volume: 11 Issue: 3, July, 2017. International Journal of Pure and Applied Mathematics Special Issue 963