



ISSN: 2350-0328

**International Journal of Advanced Research in Science,
Engineering and Technology**

Vol. 6, Special Issue , August 2019

**International Conference on Recent Advances in Science, Engineering, Technology and
Management at Sree Vahini Institute of Science and Technology-Tiruvuru, Krishna Dist, A.P**

Design and Development of Innovative Method to save Child from Bore Well Using Embedded System

Ch.Kutumbarao, T.Ramesh , P.Naga Sai MadhusudhanaRao

Assistant Professor, Department of Electronics & Communication Engineering,
SreeVahini Institute of Science & Technology, Tiruvuru, Krishna Dt., Andhra Pradesh, India.

ABSTRACT: This paper is based on the recovery of children who fallen into borewell. Due to drought and depletion of underground water more bore wells are drilled on the surface of the earth. When the ground water gets dried or polluted nearby industries, the motor along with casing pipe are removed and the outer, surface of the bore is not insulated properly. As a result of this, the children who were playing near the bore, accidentally fall into it which has drunk their lives. This aids to recover the children from the bore well without any danger of the victim. The sensor systems are interfaced with the ARM8.5-A processor. A camera along with anDECO LED light is used to visualize the victim as well as it helps to operate the system by control unit. The vacuum cup is used to adjust the child position. The arm movement of the robot is controlled by stepper motor. Once child is perfectly picked by robot, 24v M15H1 BLDC(Brushless DC Motor) motor is used to lift up the child from borewell. The ZigBee plays a vital role of data transferring between the victim in borewell and the recovery team in earth surface. The simulation results are obtained by using the software Keil C. The hardware output is implemented and the results are shown.

KEY WORDS: ARM 8-5A processor, DECO LED, Vacuum cup, Sensors,ZigBee, BLDC Motor.

I. INTRODUCTION

In present time falling of children and even adults in bore well are very increasing. These accidents are mainly happened due to carelessness or playful activities of the child, moreover most of the bore wells are drilled and leaved as it is open without any proper coverings. When a child fall into the bore well the existing rescue operations in such cases are more risky and become a non-safe to the rescue team members.

In existing system, a big hole is dug beside the bore well up to the depth where the child is stuck. This process a huge amount of human resources (military, Paramedical, etc.), machinery (JCBs, Tractors, etc.) is used. A small delay in this resources accumulation may reduce the chances of saving child alive. If the area beside the bore hole contains rocks below certain depth, in such cases the chance of saving child alive is very low. Whatever may be the case the success ratio depends on lots of factors like availability of time taken for transportation of machinery to the situation, human resources and mainly the response time of various government organizations. In India according to the NCRB report of 2011 there are 5 average deaths per day in the license bore wells. At present there is no proper solution for this problem; in this paper the model of a robot arm which can be used for rescue operation is briefly explained

II. LITERATURE SURVEY

Bharathi et-al [1] describes the designing a robot for rescue a child from inside bore well, which is capable of moving inside the bore well, according to the human comment by PC and also pick and placing based on arm design. . The robot is operated through PC using wireless Zigbee technology and using wireless camera can view both audio and video on the TV. This robot has a high-power LED which acts as a light source when light intensity inside the pipe is low. It is a low cost robot used to monitor and the human controlled robot that gives an insight view of rescuing the baby safely taken to achieve this.

Palwinder Kaur et-al [2] describes the rescue operations without human intervention. Here the wheeled leg mechanism is design to go inside the pipe and the legs are circumferentially and symmetrically spaced out 120°



ISSN: 2350-0328

International Journal of Advanced Research in Science, Engineering and Technology

Vol. 6, Special Issue , August 2019

International Conference on Recent Advances in Science, Engineering, Technology and
Management at Sree Vahini Institute of Science and Technology-Tiruvuru, Krishna Dist, A.P

apart. The robot can adjust its legs according to the pipeline dimensions. The robot has consisting of power supply, switch pad, and gear motor. The child position is captured from bore well with USB Camera and monitored on PC. The LM35 temperature sensor and 16*2 LCD are interfaced with PIC 16F877A microcontroller to sense and displays on LCD.

Manish Raj *et-al* [3] describes as the diameter of the borewell is narrow for any adult person and light goes dark inside it, the rescue task those situations is challenging. The robotic system which will attach a harness to the child using pneumatic arms for picking up. A teleconferencing system will also attach to the robot for communicating with the child.

John Jose Patteryet-al [4] describes the facility to monitor the trapped child, supply oxygen and provide a supporting platform to lift up the child. The 1st motor placed at top turns a gear mechanism which, in turn, pushes 3 blocks arranged at 120 degrees from each other towards the side of the bore well. The 2nd motor placed below the plate turns the bottom shaft by 360 degrees, the helping to locate the gap through which the lifting rod passes. This is done with the help of a wireless camera attached to the lifting rod.

The 3rd. motor adjusts the radial distance of the lifting rod. When the diameter is adjusted, the 4th motor helps the lifting rod to screw its way through the gap towards the bottom of the child. Once the lifting the rod reaches a safe position under, an air compressor is operated to pump air to the bladder attached to the end of lifting rod through an air tube that runs downwards inside the lifting rod. The bladder provides a safe seating to the child. Then 1st motor is then reversely operated so as to unclamp the system. Simultaneously it is lifted out of the well using a chain or rope.

In the existing system, if the child fell into the bore well. The rescue workers dug the hole near the bore well to save the child. It's fully manual and more harmful during the rescue operation. The presence of the child in the borewell is not identified by the rescue workers. So it's the time consuming process and the oxygen present in the bore well is very low. This may lead to death of the child. To overcome this automation system is implemented.

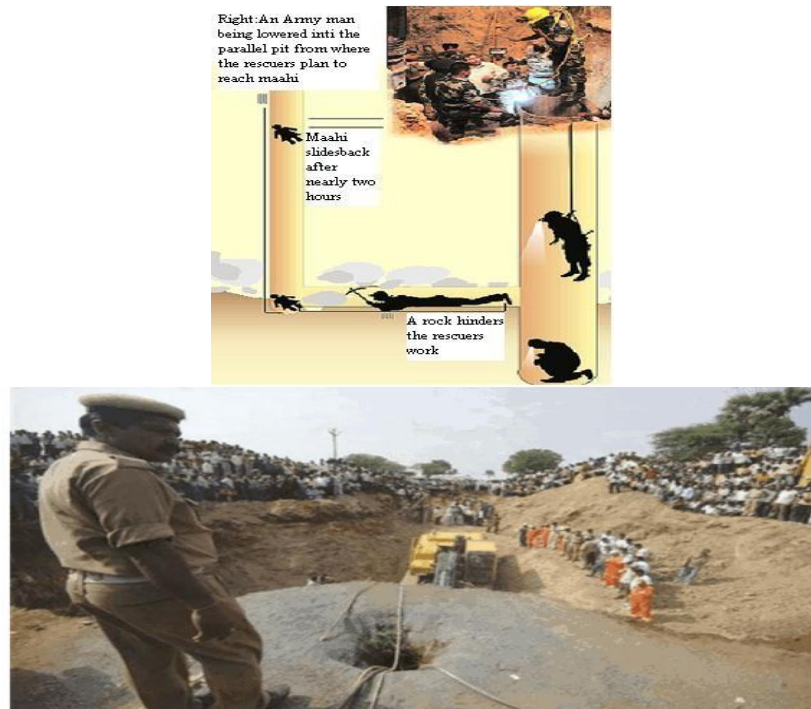

Existing Rescue Method

III. DEVELOPED RESCUE ROBOT SYSTEM

The system is divided into two separate units, one is Transmitter (controller) unit and another one is Receiver (Robot) unit. The unit which is inside the bore well is controlled by the keypad controller. In this robot, low-power digital radios based on the IEEE 802.15.4 ZigBee standard for Wireless Personal Area Networks (WPANs) is used and it transmit 1 to 1000meters (about 3 to 3.280 feet) signals. Here the temperature measured by thermistors, for pressure transducer are used to measure the pressure and the poisonous gas detectors is used to find the proportion of hydrocarbons, methane, volatile organic compounds in parts per million(ppm). These measured values of temperature, pressure and poisonous gases are shown in PC.

During the rescue operation the robot setup is sent to the bore well till the victim is found, Later the parameters are sensed by the sensors. The transmitter in borewell is used to send the signal of temperature, pressure and presence of poisonous gaseous. If any poisonous gas is detected, oxygen provided through the oxygen probe from atmospheric air can externally pumped into the bore well till the ratio of poisonous gas of inside bore well is reduced.

Using ZigBee these signals are transmitted to controller setup. These processes are monitored with help of camera. The camera along with high power Light Emitting Diode (LED) torch is provided to visualize and monitor the child movement inside of borewell in a clear manner.

Fig.1. Rescue Robot unit

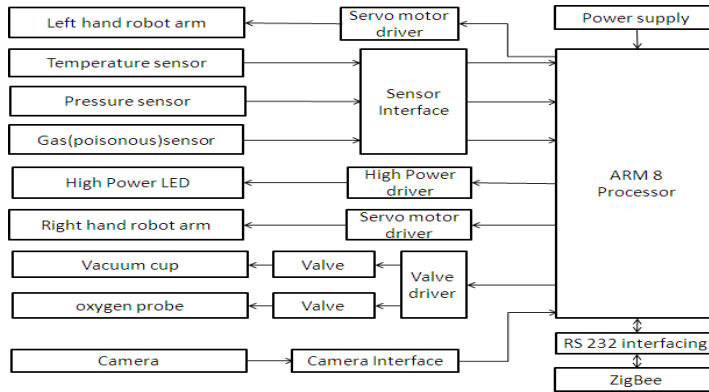
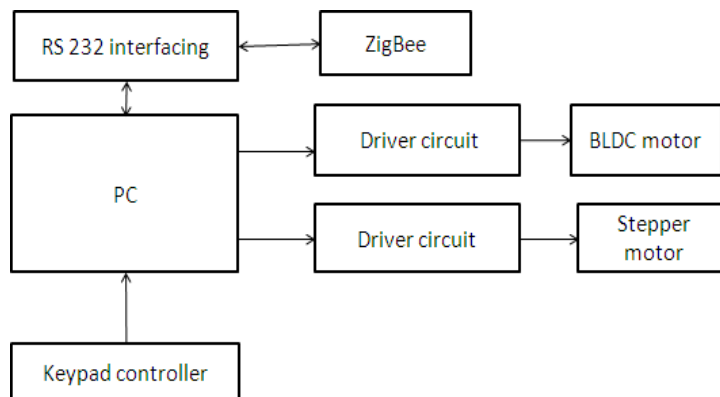

Fig2. Control unit



IV. EXPERIMENTAL RESULTS

Keil C μ Vision4: The new Keil μ Vision4 IDE has been designed to enhance developer's productivity, enabling faster, more efficient program development and it helps to provide the variation simulation output.

Fig-3: Keil C output

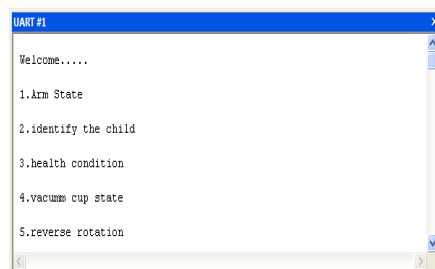

International Journal of Advanced Research in Science, Engineering and Technology

Vol. 6, Special Issue , August 2019

International Conference on Recent Advances in Science, Engineering, Technology and
Management at Sree Vahini Institute of Science and Technology-Tiruvuru, Krishna Dist, A.P

PROPOSED SYSTEM



V. CONCLUSION AND FUTURE WORK

This system is mainly used for rescue child from borewell. Here the proposed system consists of ZigBee transmitter, ARM 8 processor, robot arm and the sensors perform their role in these operations. In past 10 years, a lot of lives have been lost due to falling in bore well because digging a pit beside the bore well is very tedious and time consuming process. The rescue operation team using this technology is so safe and the rescue operation time is very less. Using highly advanced IC's with the help of growing technology this project can be successfully implemented. This can be conclude that, the proposed system retain lives of many who fell into the bore well infuture.

REFERENCES

- 1]. B.Bharathi, B. Suchitha Samuel "Design and Construction of Rescue Robot and Pipeline Inspection Using ZigBee" International Journal of Scientific Engineering and Research (IJSER) Volume 1 Issue 1, September 2013.
- [2]. Palwinderkaur,Ravinderkaur,Gurpreetsingh "Pipeline Inspection And Bore well Rescue Robot"International Journal of Research in Engineering and Technology(IJRET) Volume issue:03 Issue:04|April2014.
- [3]. Manish Raj, P.ChakrabortyandG.C.Nandi "Rescue robotics in bore well Environment" Cornell university library [v1] Mon, 9 Jun 2014 10:51:44 GMT(244kb).
- [4]. John Jose pottery "robot for bore well rescue" amaljothi college of engineering vol 10, Jun2009.



ISSN: 2350-0328

International Journal of Advanced Research in Science, Engineering and Technology

Vol. 6, Special Issue , August 2019

International Conference on Recent Advances in Science, Engineering, Technology and
Management at Sree Vahini Institute of Science and Technology-Tiruvuru, Krishna Dist, A.P

- [5]. Dr. C.N. Sakhale, D.M. Mate ,SubhasisSaha, TomarDhampal, PranjitKar, Arindam Sarkar,Rupam Choudhury, ShahilKumar “An Approach to Design of Child saver Machine for Child Trapped in Borehole” International Journal of Research in Mechanical Engineering volume 1, Issue 2, October- December,2013,pp.26-38.
- [6]. G. Nithin, G. Gowtham, G. Venkatachalam and S. Narayanan “Design and Simulation of Bore well rescue robot-Advanced” Asian Research Publishing Network (ARPN) Journal of Engineering and Applied Sciences
- [7]. K.Saran, S.Vignesh, Marlon Jones Louis “Bore-well Rescue Robot” international journal of research aeronauticalandmechanicalengineering(IJRAME) vol1,issue4,pg.61-80,April2014.
- [8]. Sakthivel.T, Sindhulakshmi.K, Bruntha.M. Radhika “Surveillance precision using borewell navigation borewell” An International Journal of Advanced Computer Technology, ISSN: 2320-0790, April 17, 2014.
- [9]. SureshKumar.N, K.V.K.V.L.Pavan Kumar, Mahesh.G “International Journal of Applied Engineering Research” ISSN 0973-4562 Volume 9, Number 17 (2014) pp. 3977-3983.
- [10]. Sridhar Palaniswamy “ Life Saving Machine” the first International Conference on Interdisciplinary Research and Development, 31 May-1 June 2011, Thailand.
- [11]. Shukla Shubhendu S, Applicability of Artificial Intelligence in Different Fields of Life, International Journal of Scientific Engineering and Research, pp. 28-35,2013.
- [12]. R.M.Voyles, S. Povilus, Kang Li.RecoNode: A Reconfigurable Node for Heterogeneous Multi-
- 1]. B.Bharathi, B. Suchitha Samuel “Design and Construction of Rescue Robot and Pipeline Inspection Using ZigBee” International Journal of Scientific Engineering and Research (IJSER) Volume 1 Issue 1, September 2013.
- [2]. Palwinderkaur,Ravinderkaur,Gurpreetsingh “Pipeline Inspection And Bore well Rescue Robot”International Journal of Research in Engineering and Technology(IJRET) Volume issue:03 Issue:04|April2014.
- [3]. Manish Raj, P.ChakrabortyandG.C.Nandi “Rescue robotics in bore well Environment” Cornell university library [v1] Mon, 9 Jun 2014 10:51:44 GMT(244kb).
- [4]. John Jose pottery “robot for bore well rescue” amaljothi college of engineering vol 10, Jun2009.
- [5]. Dr. C.N. Sakhale, D.M. Mate ,SubhasisSaha, TomarDhampal, PranjitKar, Arindam Sarkar,Rupam Choudhury, ShahilKumar “An Approach to Design of Child saver Machine for Child Trapped in Borehole” International Journal of Research in Mechanical Engineering volume 1, Issue 2, October- December,2013,pp.26-38.
- [6]. G. Nithin, G. Gowtham, G. Venkatachalam and S. Narayanan “Design and Simulation of Bore well rescue robot-Advanced” Asian Research Publishing Network (ARPN) Journal of Engineering and Applied Sciences
- [7]. K.Saran, S.Vignesh, Marlon Jones Louis “Bore-well Rescue Robot” international journal of research aeronauticalandmechanicalengineering(IJRAME) vol1,issue4,pg.61-80,April2014.
- [8]. Sakthivel.T, Sindhulakshmi.K, Bruntha.M. Radhika “Surveillance precision using borewell navigation borewell” An International Journal of Advanced Computer Technology, ISSN: 2320-0790, April 17,2014.
- [9]. SureshKumar.N, K.V.K.V.L.Pavan Kumar, Mahesh.G “International Journal of Applied Engineering Research” ISSN 0973-4562 Volume 9, Number 17 (2014) pp. 3977-3983.
- [10]. Sridhar Palaniswamy “ Life Saving Machine” the first International Conference on Interdisciplinary Research and Development, 31 May-1 June 2011, Thailand.
- [11]. Shukla Shubhendu S, Applicability of Artificial Intelligence in Different Fields of Life, International Journal of Scientific Engineering and Research, pp. 28-35,2013.
- [12]. R.M.Voyles, S. Povilus, Kang Li.RecoNode: A Reconfigurable Node for Heterogeneous Multi-