



ISSN: 2350-0328

**International Journal of Advanced Research in Science,
Engineering and Technology**

Vol. 8, Issue 2 , February 2021

Development of a Separator-Cleaner and Substantiation of Its Main Parameters

E.B.Qurbanbayev, Q.Jumaniyazov, A.A.Akramov

Researcher , JSC «Pakhtasanoat research center», Tashkent, Uzbekistan
Doctor of Technical Sciences, Professor, JSC «Pakhtasanoat research center», Tashkent, Uzbekistan
PhD of technical Sciences, JSC «Pakhtasanoat research center», Tashkent, Uzbekistan

ABSTRACT: The article presents the results of research work carried out by JSC "Paxtasanoat ilmiy markazi" on the development of a separator-cleaner for raw cotton. Based on the analysis of the technology of the cleaners and the separator-cleaner, the type of the working body was selected in the form of air-permeable slatted drums with attached rubber-fabric plates along the entire length of the drum. The use of air-permeable slatted drums together with existing pegs helps to reduce the ignition of raw cotton. A separator-cleaner containing six air-permeable slat drums and five perforated grids, located in a sealed casing, was developed and tested using the method of mathematical planning of experiments.

KEY WORDS: cleaning effect, air-permeable slatted drum, optimization, raw cotton, clogging, separator-cleaner.

I. INTRODUCTION

For pneumatic transportation of raw cotton since the beginning of the 60s of the last century, SS-15A scraper separators equipped with perforated nets and scrapers in the sidewalls have been used. They are morally outdated, and their cleaning effect on small organic and mineral trash impurities does not exceed 5-10% [1], which practically does not affect the total cleaning effect of the equipment of cotton ginning plants. In addition, due to the uneven supply of raw cotton and with its increased moisture and clogging, the perforated nets of these separators are relatively often clogged, they are urgently stopped and manually cleaned of raw cotton, which leads to downtime of the separators and a decrease in the productivity of ginneries. In addition, wear on perforated screens, scraper blades and vacuum valves is accelerated.

II. OBJECT AND RESEARCH METHODS

The object of the research is a developed experimental model of a separator-cleaner with slatted drums. Research methods - determination of the main parameters and operating mode of the separator-purifier using the method of mathematical planning of the experiment.

III. MAIN PART

In scientific center developed and manufactured an experimental sample of the separator-cleaner [2], the study of which revealed high aerodynamic resistance. High aerodynamic resistance due to the passage of the air separator-purifier sucked out of the hopper, first between the peg conveyor drums, and then between the grates of the grate. Moreover, the pegs drums have solid shells with welded-in pegs, the height of which above the shells is much less than the shell diameters.

The air in the gaps between the rotating drums and between the grate bars overcomes flow restrictions and eddies. Moreover, the aerodynamic resistance of the transporting drums depends on their design and rotation frequency, as well as on the ratio of the total area of the gaps between them in the cross-section along the plane of the rotation axes of the drums to the total area of their section. Moreover, the diameters of the drums and the dimensions of the gaps between them are optimized to ensure maximum productivity and the cleaning effect of the separator-cleaner.

The aerodynamic drag of the grate depends on the ratio of the area of the gaps between the grates to the total cross-sectional area in the plane of the longitudinal axes of the grate and is characterized by the coefficient of the so-called "free section", which is 44.4% for grate grates. Due to the high aerodynamic resistance of the separator-cleaner, increased air pressure losses occur in it, as a result of which high-pressure fans with high-power electric motors are used for pneumatic transportation of raw cotton through pipelines to the separator-cleaner and through it.

Based on the above, further research at TsNIIHprom developed and manufactured air-permeable slatted drums with attached rubber-fabric plates along the entire length of the drum together with existing peg drums [3].

The strips are made in the form of unequally shelving corners attached to the cutouts on the periphery of the discs in such a way that the large shelves of the corners are directed radially from the shafts, and rubber-fabric plates are attached to them. The corners are attached to each cutout on the periphery of the discs with two bolts in mutually perpendicular directions.

The cross-section of the air-permeable slatted drum is shown in Fig. 1. The section shows a disk 2 mounted on a shaft 1 with notches on the periphery, to each of which two bolts 3 and 4 are attached unequally shelf angle in mutually perpendicular directions 5. Moreover, a large angle shelf is directed radially from the axis of rotation of the drum and to it with bolts 6 and a rubber-fabric plate 8 is attached with nuts 7.

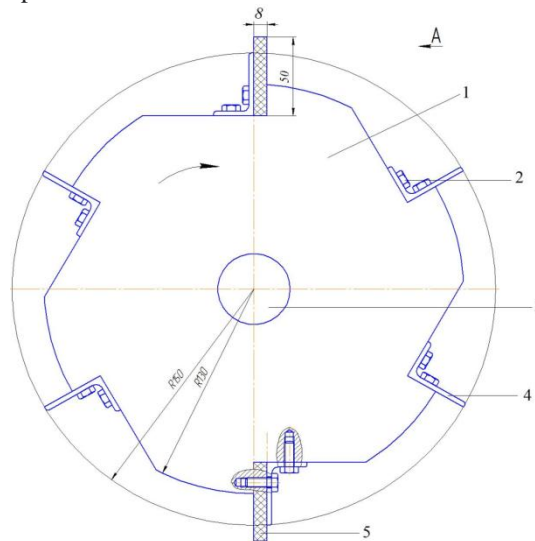

Figure 1. Scheme of an air-permeable slatted drum for transporting raw cotton along a perforated mesh of a separator-cleaner.

1 - discs, 2 - bolts for fastening corners to discs, 3 - shaft, 4 - unequal corners, 5 - rubber-fabric strips.

Air-permeable structural elements are made in the form of perforated meshes with a cross-section ratio of at least 50%. The execution of the transporting drums as slatted, the strips of which are attached to the disks mounted on the rotation shafts of the drums, ensures their air permeability, since with such a design, a continuous airtight shell is not used in the drums. As a result, the air sucked through the hopper passes not only through the gaps between the transporting drums, but also through their internal cavities, which reduces their aerodynamic resistance in comparison with peg drums with solid shells.

The execution of the strips in the form of unequally shelving corners attached to the cutouts on the periphery of the discs in such a way that the large shelves of the corners are directed radially from the shafts, provides the possibility of bolting rubber-fabric plates to them, which will also be directed radially. The use of rubber-fabric plates and their radial arrangement relative to the drum shafts is optimal for non-traumatic and reliable transportation of raw cotton along breathable structural elements and should help to reduce the ignition of raw cotton.

The fastening of the corners to each cutout on the periphery of the discs with two bolts in mutually perpendicular directions prevents the possible self-loosening of the bolts under the influence of microvibrations arising from the rotation of the drums.

With the use of air-permeable slatted drums, JSC "Paxtasanoat ilmiv markazi" has developed and manufactured an improved separator-cleaner for cotton, which is shown in fig. 2 [4].

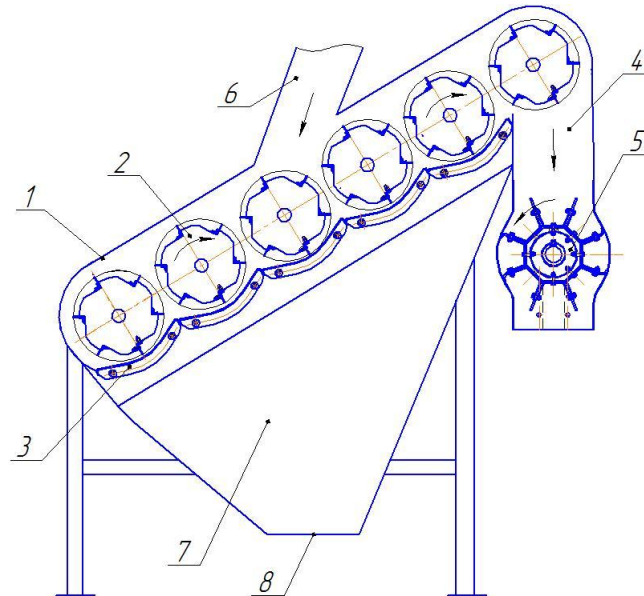

Figure 2. Scheme of a separator-cleaner of raw cotton

1 - sealed body, 2 - air-permeable slatted drum, 3 - perforated mesh, 4 - shaft, 5 - vacuum valve, 6 - diffuser, 7 - hopper, 8 - docking hole for connection to the pipeline.

The separator-cleaner for raw cotton (Figure 2) contains six air-permeable slatted drums 2 and five perforated nets 3 located in a sealed housing 1, installed under the first five slatted drums, and under the sixth last along the course of the raw cotton, the upper slatted drum will have a shaft 4 and a vacuum valve 5 at its bottom. A diffuser 6 must be docked to the body 1 above the third and fourth slatted drums 2, which will be connected to the pipeline (not shown in the figure), and under the perforated nets 3, a hopper 7 with a docking hole 8 must be attached to the body, to which the pipeline will be connected for air suction (not shown in the figure).

The separator-cleaner will work as follows. When air is sucked out of the hopper 7, the air vacuum created in this case will spread through the holes of the perforated nets 3 and through the air-permeable slatted drums 2 into the housing 1 and into the diffuser 6, and then into the pipeline (not shown in the figure), through which the raw cotton will be transported.

Raw cotton from the diffuser will fall under the influence of slatted drums 2 and be transported by them first from above to the lower slatted drum, and then along perforated nets 3 to the upper slatted drum, which will direct the raw cotton through shaft 4 to the vacuum valve 5, which will unload the cotton - raw from the separator-cleaner.

As a result of the shock effects of the strips of the air-permeable drums 2, the raw cotton will loosen, and small organic and mineral trash impurities will be released from it, which will be carried out by air currents through the holes in the perforated nets 3 into the hopper 7, from which trash impurities through the docking hole 8 transported by air through the pipeline to the fan and from it is sent to the cyclone, where the trash will be separated from the transporting air.

Full-factor experiments were carried out to determine the parameters and operating mode of the developed separator-purifier. The criteria for assessing the quality of the cotton separator-cleaner is the general cleaning effect of U1 and the increase in damage to seeds U2. The main factors influencing these criteria are: the gap between the drums and the mesh S, the rotation speed of the drums V and the performance of the separator-cleaner.

When carrying out experimental studies, the plan of a multifactorial experiment B3 was vibran.

Based on the results of preliminary studies, the levels and steps of variation of the factors influencing the quality of cleaning were selected (Table 1).

Table 1
Factor levels and intervals of their variation

№	Factors	Unit	Identification factors		variation intervals	Variation levels		
			Natural	coding		-1	0	+1
1	The gap between the drums and the net	mm	S	X ₂	5	5	10	15
2	Drum rotation speed	rpm	V	X ₂	100	350	450	550
3	Separator-purifier performance	t / h	P	X ₃	2	8	10	12

As a result of processing the experimental data using computer software, the following regression equations were obtained, which adequately describe the cleaning process by the separator-purifier.

$$Y_1 = 43,143 - 0,413X_1 - 5,650X_2 - 0,716X_3 - 1,060X_1^2 - 0,204X_1X_2 - 12,110X_2^2 - 0,370X_2X_3 + 0,322 X_3^2 \quad (1)$$

$$Y_2 = 0,483 - 0,010X_1 + 0,080X_2 + 0,039X_3 - 0,068X_1^2 + 0,029 X_2^2 - 0,007X_2X_3 + 0,059 X_3^2 \quad (2)$$

When solving the issue of optimizing the parameters of the separator-cleaner, the following conditions were taken:

$$Y_1 \rightarrow \max \quad Y_2 \leq 0,5$$

The parameters are optimized using modern computer programs using random search methods. As a result, the following optimal parameters of the technological process were obtained:

Factor values	X ₁	X ₂	X ₃
Coded	-0,17405	-0,21649	-1
Natural	9,12975	428,3507	8
Rounded	10	430	8

Based on the results of the results of multifactorial studies, we take a rational value: the gap between the drums and the mesh is 10 mm, the rotation speed of the slatted drums is 430 rpm and the productivity of the separator-cleaner is 8 t / h.

IV. FINDINGS

Based on the results of the work carried out, it can be concluded that an improved separator-cleaner with slatted drums has been developed, which will replace the existing separator SS-15A, with a simultaneous increase in the cleaning effect from fine litter.

REFERENCES

- [1]. Handbook on the primary processing of cotton, book II, NPO "Khlopkoprom", Tashkent, "Mekhnat", 1994
- [2]. Separator-cleaner of raw cotton from fine litter. Cotton industry. № 2. Tashkent, 1978.S. 21-22
- [3]. Q.Jumaniyazov, R.R. Nazirov, E.B. Kurbanbayev "Development of the construction of a breathable slatted drum" Innovative ideas and developments of talented young people in the context of modernization of cotton ginning textile light industry, printing production techniques and technologies. Republican collection of scientific and practical theses. Tashkent 2020y Part I pages 46-47.
- [4]. Q.Jumaniyazov, E.B. Kurbanbaev, P.N. Borodin "Development of the scheme of the separator-cleaner of raw cotton and the design of the air-permeable slatted drum" Collection of scientific articles INNAVATION 2019 Tashkent 2019 y 340-341 p