



ISSN: 2350-0328

**International Journal of Advanced Research in Science,
Engineering and Technology**

Vol. 8, Issue 5 , May 2021

Development of a New Cotton Regenerator to Remove Cotton Boats from Cleaner Waste

Turdiyev Hayotbek Ergashboyevich , Toshmirzayev Qodirjon Odiljonovich , Komilov Jasurbek Nabijanovich

Assistant, Fergana Polytechnic Institute, Repablik of Uzbekistan
Assistant, Fergana Polytechnic Institute, Repablik of Uzbekistan
Assistant, Fergana Polytechnic Institute, Repablik of Uzbekistan

ABSTRACT: The article presents the results of research work on the development of a new cotton regenerator for the extraction of cotton volatiles from waste cleaners. The main distinguishing features of the design and technological process of the new cotton regenerator for the extraction of cotton volatiles from waste cleaners are described.

KEY WORDS: cotton regenerator, breathable, bar drum, axial, cleaning ratio, screw.

I. INTRODUCTION

It is known that the main disadvantages of a serial regenerator are associated with the designs of the pneumatic feeder and working bodies [1, 2]. At the same time, the use of two capture drums - the main one and the regeneration one - is sufficient and acceptable for the developed regenerator.

The serrated drums of the RX regenerators have a diameter of 480 mm, while the modern grasping saw cylinders are made from over-cut genie saws with a diameter of 300 mm. Accordingly, with a decrease in the diameter of the cylinder, the arc length of the grate arrangement decreases, and while maintaining the optimal gaps between them equal to 40 mm, their number decreases from 10 to 6 pieces. at the main drum and from 15 to 8 pcs. have regenerative. Due to a decrease in the number of grates, a slight decrease in the cleaning effects will occur, which will be compensated by an increase in the frequency of cleaning the regenerated fumes from 3-4 times to 6, 8 times.

Taking into account the revealed shortcomings of the semi-cylindrical pneumatic feeder in the developed regenerator, it is advisable to form a channel from the inlet to the outlet inside the housing above the stripping drum and on the side of the main gripping drum, which should be located at the opposite sidewalls.

Despite the increase in comparison with the RX regenerator by almost 2 times the distance between the inlet and outlet openings and a decrease in the channel cross-sectional area in comparison with the semi-cylindrical feeder, a part of the small trash impurities and free fiber in the waste will transit without entering the main gripping saw cylinder.

To prevent such a transit in the channel, it is advisable to arrange an air-permeable bar drum along its longitudinal axis with the bars arranged along a helical line. When rotating, such a drum will swirl the air flow around itself with an axial displacement in the direction from the inlet to the outlet. Due to this, the waste moving with the air flow will repeatedly pounce on the surface of the main gripping saw cylinder. In this case, the frequency of supply of waste and regenerated volatiles can be adjusted by the rotation speed of the bar drum.

The developed scheme of the regenerator is shown in Figure 1. The following main working bodies are installed in the body of the regenerator: bar drum 1, main 2 and regeneration 3 saw cylinders, working in combination with fixing 4, 5 and cleaning 6, 7 grates, removing slatted drum 8 and scorching auger 9, to the discharge opening of which a tube 10 with a valve is connected. The screw 9 and the tube 10 are borrowed from the serial RX regenerator.

The upper cover 11, front 12 and rear 13 walls adjoin the sides of the regenerator body. The front wall 12 and the top cover 11 have inlet 14 and outlet 15 openings located at opposite sides. To them are connected, respectively, inlet 16 and outlet 17 branch pipes. The body also contains the enclosing trays 18, 19, 20 forming the channel, the shield 21, the guide trays 22, 23 and 24, the enclosing casing 25 and the trough 26.

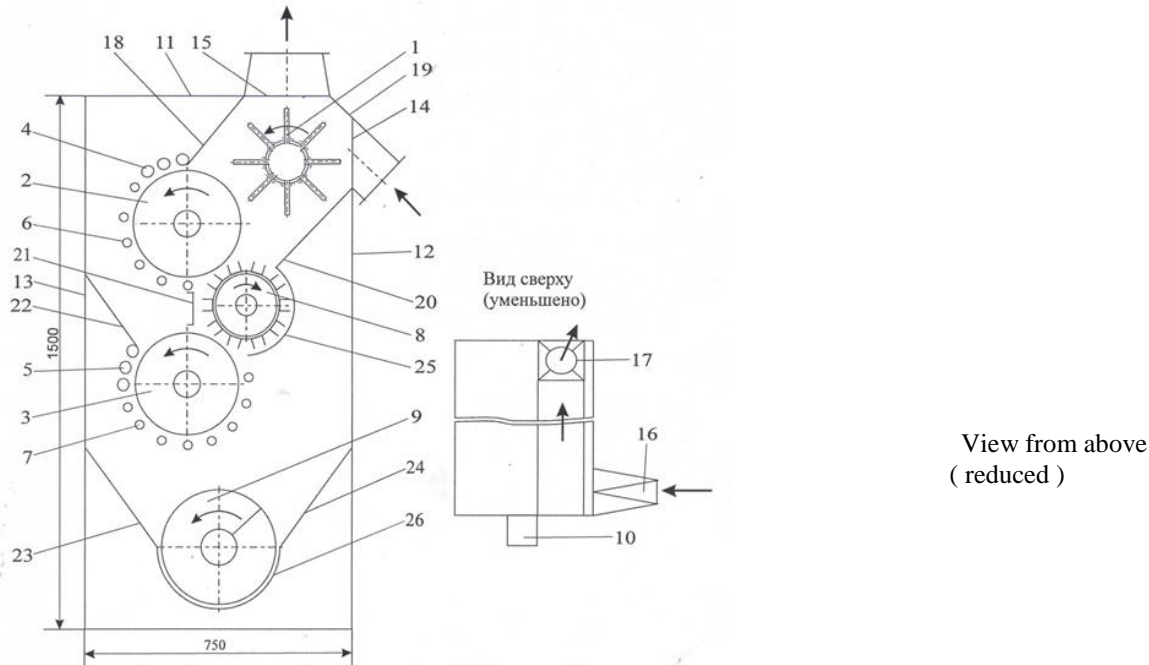

1-bar loosening drum, 2, 3-main and regeneration saw cylinders, 4, 5-fixing grates, 6,7-cleaning grates, 8-slat removing drum, 9-scraper auger, 10-tube with valves, 11- upper cover, 12, 13-front and back wall, 14, 15-inlet and outlet, 16, 17-inlet and outlet, 18,19,20-guard trays, 21-shield, 22, 23, 24-guide trays, 25-guarding casing, 26-trough.

Figure 1. Schematic diagram of a new raw cotton regenerator.

The work of the new regenerator of raw cotton from the waste of cleaning equipment will be carried out as follows.

The air vacuum created by the fan through the condenser or separator through the pipeline (not shown in the figure), connected to the outlet pipe 17, spreads through the channel formed by the enclosing trays 18, 19 and 20, as well as parts of the upper cover 11 and the front wall 12, spreads into the body of the regenerator and in a pipe connected to the inlet pipe 16 (not shown in the figure), into the open end of which the outside air and the waste transported by it, as in the RX regenerators, are sucked.

From the branch pipe 16, the air and the waste transported by it through the inlet 14 enter the channel formed by the trays 18, 19 and 20 and parts of the upper cover 11 and the front wall 12 and come under the influence of the bar drum 1, which rotates in the same direction with the saw cylinders 2 and 3 (counterclockwise on the diagram).

The bar drum 1 loosens the incoming waste and throws it onto the saw cylinder 2, the teeth of which capture the raw cotton volatiles in the waste, and also transfer the entire mass of waste to the zone of grates 4 and 6.

The raw cotton flies are fixed on the saw teeth of cylinder 2 by fixing grates 4, the gaps between which are less than the linear dimensions of the flies, which does not allow them to be separated from the saw teeth, and then, when they collide with the grates 6, they are cleaned of trapped impurities, but free, not adhered to the raw cotton volatiles, weed impurities are separated from the saw cylinder 2 under the action of centrifugal forces and are released through the gaps between the grates 6.

Partially cleaned regenerated raw cotton volatiles and trash impurities remaining on the saw cylinder 2 after passing through the grate zone 6 are removed from it by a removing slatted drum 8 and thrown into the channel in which air moves from the inlet 14 to the outlet 15 due to vacuum and under the influence of the bar drum 1 axially, that is, along a helical line.

Thus, the rotating bar drum 1 prevents the direct movement of air from the inlet 14 to the outlet 15 and, accordingly, practically eliminates the transit of waste without being fed to the saw cylinder 2. The regenerated volatiles and trash impurities carried away by the air flow are displaced to the outlet 15 and re-pounce on saw cylinder 2, on which the above-described cleaning process is repeated. The rate of supply of waste and regenerated volatiles to the saw cylinder 2, that is, the rate of their cleaning, depends on the air flow rate through the channel and on the linear speed of rotation of the bar drums.



ISSN: 2350-0328

International Journal of Advanced Research in Science, Engineering and Technology

Vol. 8, Issue 5, May 2021

The trash impurities and part of the regenerated raw cotton volatiles that have fallen out through the gaps between the grates 6 fall or roll down the tray 22 onto the regeneration saw cylinder 3, the cleaning process on which is similar to that described on the main saw cylinder 2. Raw cotton volatiles that have been cleaned on the regeneration saw cylinder 3 are removed from it by a slatted drum 8, slide over the flap 21 and mixed with the bats removed by it from the main saw cylinder 2, after which they are fed together into the channel.

The impurities that have fallen out through the gaps between the grates 7 fall on the auger 9 or through the trays 23 and 24 fall into its trough 26, after which the auger 9 is discharged from the regenerator through the tube 10 with a valve.

Regenerated raw cotton volatiles moving in the channel along a helical line and upon reaching the outlet 15 are sucked together with air into the outlet 17 and then transported through the attached pipe to a separator or condenser (not shown in the figure), after which, depending on the chosen technology, they processors are either mixed with the raw cotton supplied to the refining equipment, or accumulated and then processed separately from the supplied raw cotton.

In the new regenerator, in contrast to the RX regenerator, the incoming waste under the influence of the bar drum 1 is loosened, and their layer is stretched along the length and decreases in thickness, which will ensure their supply to the saw cylinder 2 in a more uniform layer without accumulation, resulting in the throughput saw cylinder 2 should increase.

To drive two saw cylinders 2 and 3, bar drum 1 and auger 9, by analogy with the RX regenerator, an electric motor with a power of 4.0 kW is sufficient, and to drive a slatted drum - with a power 3.0 kW.

The diameters of the sawing cylinders 2 and 3 for the new regenerator were chosen equal to 300 mm, based on the calculation of using expired genie saws for the manufacture of saw blades. The diameter of the stripping slatted drum 8, since it is made using a shaft from a serial brush drum with discs with a diameter of 200 mm, is chosen equal to 286 mm. The diameter of the bar drum 1 is chosen equal to 300 mm. The design of the scorching auger 9 with the unloading tube 10 is completely borrowed from the serial RX regenerator.

At present, a cotton regenerator has been manufactured at the "RIM Factory" subsidiary and installed in the process line for cleaning cotton from coarse litter at the Baghdad ginnery, and work is underway to determine its technological parameters.

From work, the following conclusions can be drawn:

- taking into account the identified shortcomings of a semi-cylindrical pneumatic feeder in a serial regenerator, in the developed regenerator above the stripping drum and on the side of the main capture drum, a channel is formed inside the body from the inlet to the outlet, which is located on opposite sides;
- to prevent the transit of unrefined cotton in the channel, we suggest placing an air-permeable bar drum along its longitudinal axis with the bars arranged along a helical line.
- in the new regenerator, in contrast to the PX regenerator, the incoming waste under the influence of the bar drum is loosened, and their layer is stretched along the length and decreases in thickness, which will ensure their supply to the saw cylinder in a more uniform layer without accumulation, as a result of which the throughput of the saw cylinder will increase.

REFERENCES

1. Handbook on the primary processing of cotton, book I, NPO "Khlopkoprom", Tashkent, "Mekhnat", 1994.
2. "Improvement of the technological process for the processing of regenerated volatiles in order to improve the quality of the fiber and reduce the loss of cotton materials in production" (report), topic 9311, PN Borodin, RRC "Khlopkoprom", Tashkent, 1994